









# opk SAILING 4

KOMFORTABLES FALT- UND SCHIEBEÖFFNUNGSSYSTEM.  
CONVENIENT FOLDING AND SLIDING OPENING SYSTEM.  
SYSTÈME D'OUVERTURE PLIABLE ET COULISSANT PRATIQUE.

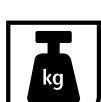
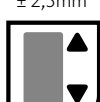

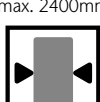
-  
-    
± 2,5mm
-    
max. 2400mm
-    
250-500mm
-    
W 18-25mm  
Frame door  
28 mm



Möbelssysteme  
Furniture systems /  
Systèmes de meubles

# opk Sailing 4



## Technische Zeichnung

Technical drawing / Plans et schémas

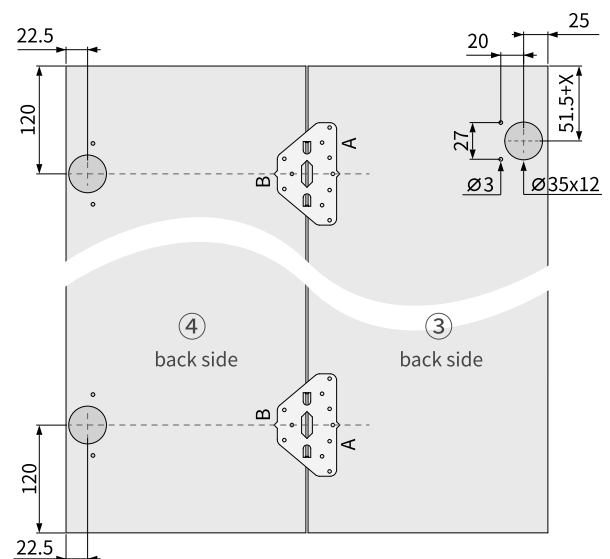
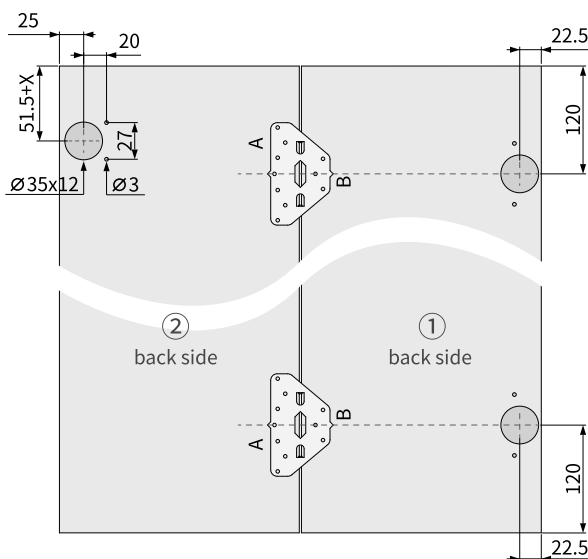
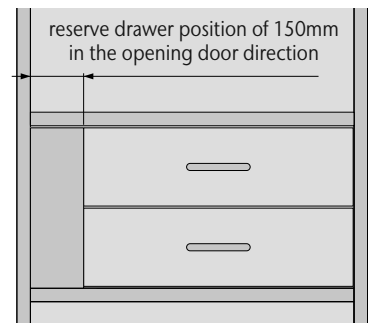
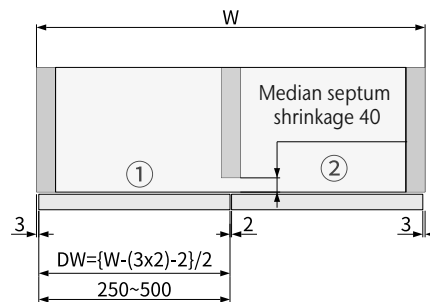
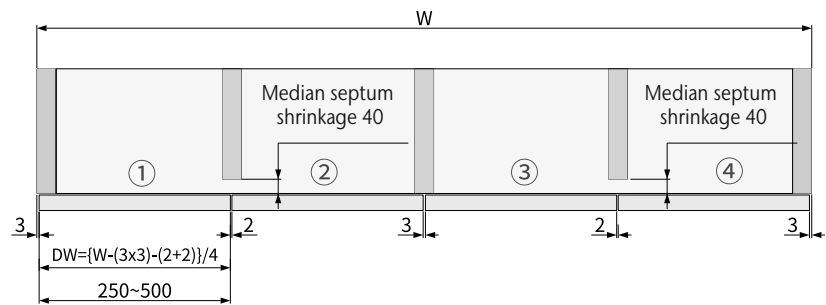
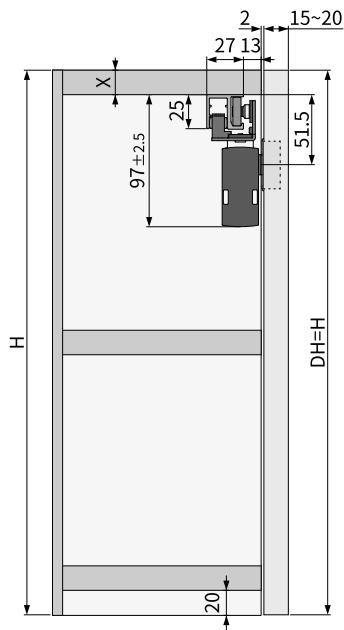

# opk Sailing 4



## Ohne Topfscharnier

Without hinge / Sans charnière



Art.-Nr./No./N° d'art.

		≤30	250-500	≤2400	01-975-000-001
--	--	-----	---------	-------	----------------

## Konfiguration für eine Doppeltür

Configuration for a double door /

Configuration pour une porte double



ohne Scharnier  
without hinge  
sans charnière

<p><b>Klappbare Hängerolle mit Dämpfung</b> <i>Folding hanging roller with damper / Rouleau de suspension pliable avec amortisseur</i></p>		1
<p><b>Stopper</b> <i>Stopper / Butée</i></p>		1
<p><b>Kunststoffscharnier</b> <i>Hinge plastic / Charnière en plastique</i></p>		2
<p><b>Bohrschablone</b> <i>Drilling pattern / Gabarit de perçage</i></p>		2

# opk Sailing 4

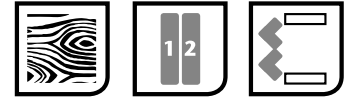

## Technische Zeichnung

Technical drawing / Plans et schémas

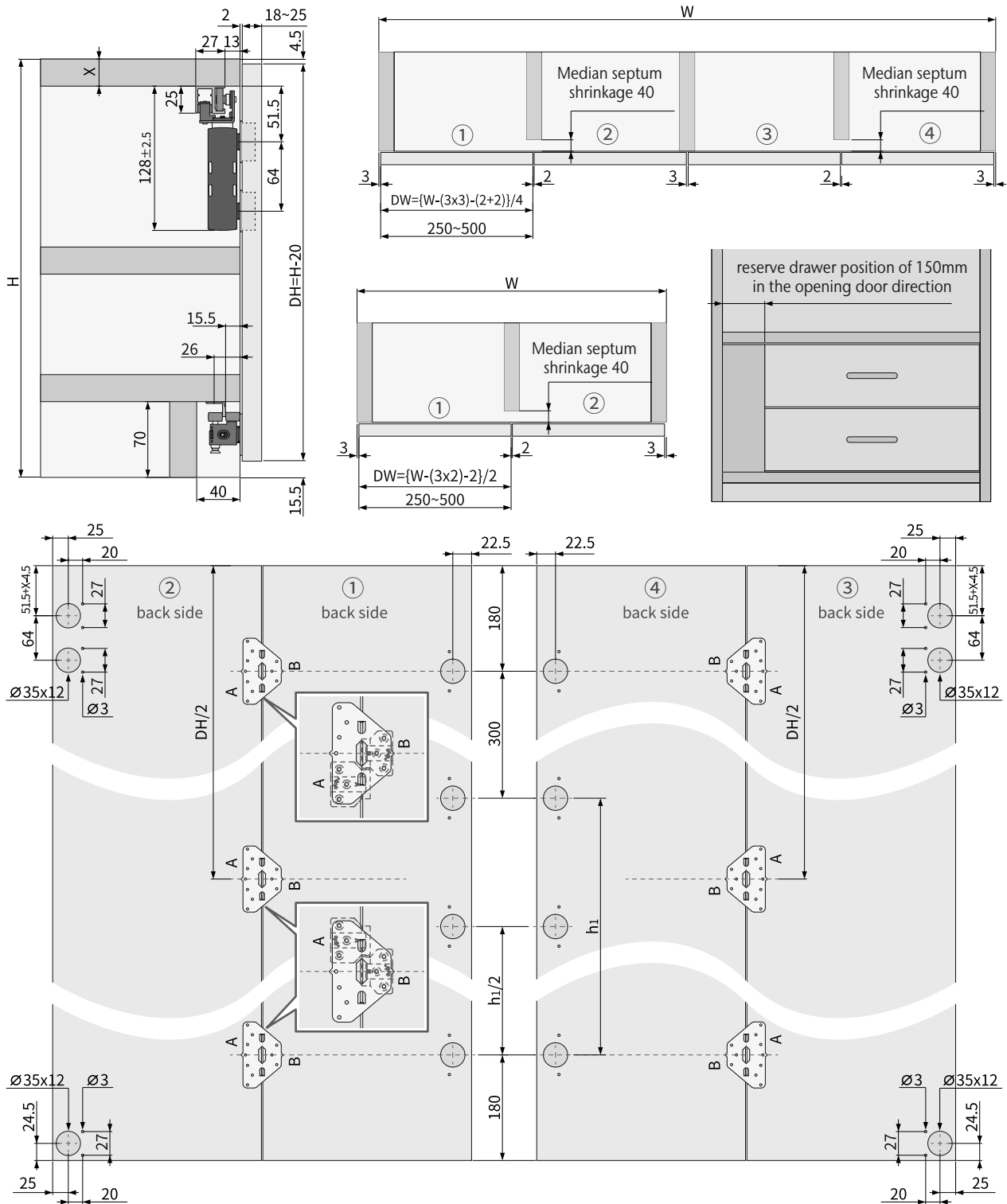

# opk Sailing 4



## Ohne Topfscharnier

Without hinge / Sans charnière



Art.-Nr./No./N° d'art.

		<p>≤30</p>	<p>250-500</p>	<p>≤2400</p>	<p>01-975-000-002</p>
--	--	------------	----------------	--------------	-----------------------

## Konfiguration für eine Doppeltür

Configuration for a double door /

Configuration pour une porte double



ohne Scharnier  
without hinge  
sans Charnière

<p><b>Klappbare Hängerolle mit Dämpfung</b> <i>Folding hanging roller with damper / Rouleau de suspension pliable avec amortisseur</i></p>		<p>1</p>
<p><b>Untere Führungsrolle</b> <i>Bottom guiding roller / Guidage inférieur</i></p>		<p>1</p>
<p><b>Stopper</b> <i>Stopper / Butée</i></p>		<p>1</p>
<p><b>Kunststoffscharnier</b> <i>Hinge plastic / Charnière en plastique</i></p>		<p>3</p>
<p><b>Bohrschablone</b> <i>Drilling pattern / Gabarit de perçage</i></p>		<p>3</p>

# opk Sailing 4



## Technische Zeichnung Technical drawing / Plans et schémas

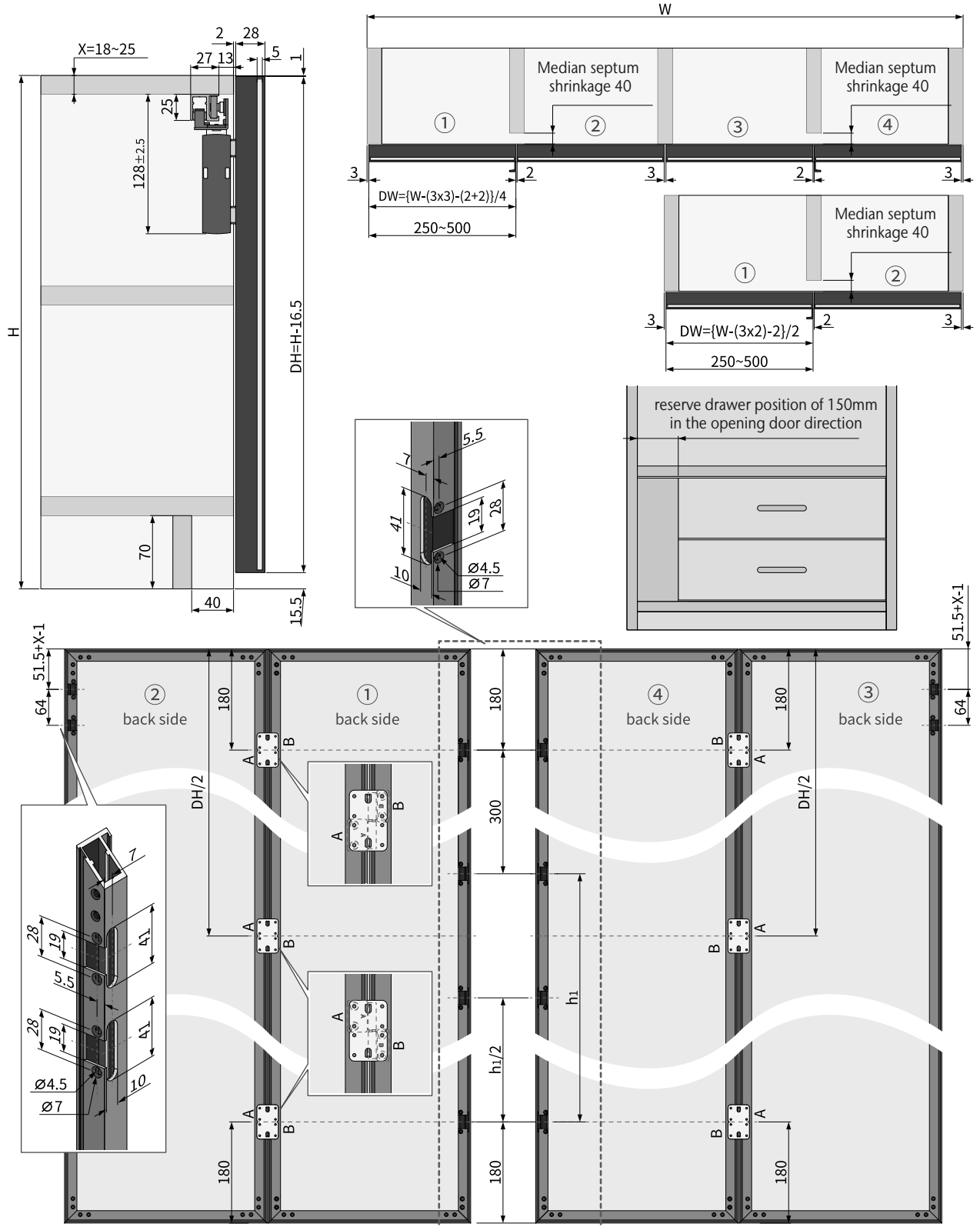

# opk Sailing 4



Art.-Nr./No./N° d'art.

		mit Scharnier with hinge 14-28mm/ avec Charnière 14-28mm	≤30	250-500	≤2400	01-975-000-004
--	--	---	-----	---------	-------	----------------

## Konfiguration für eine Doppeltür

Configuration for a double door /  
Configuration pour une porte double



mit Scharnier  
with hinge  
avec Charnière  
14-28mm

<b>Klappbare Hängerolle mit Dämpfung</b> <i>Folding hanging roller with damper/ Rouleau de suspension pliable avec amortisseur</i>		1
<b>Scharnier</b> <i>Hinge / Charnière</i>		4
<b>Stopper</b> <i>Stopper / Butée</i>		1
<b>Kunststoffscharnier</b> <i>Hinge plastic / Charnière en plastique</i>		3
<b>Bohrschablone</b> <i>Drilling pattern / Gabarit de perçage</i>		3

# opk Sailing 4



## Schienen, Zubehör

Tracks, Accessories / Rails, Accessoires

Produktbeschreibung Product description / Description du produit		Material Material / Matériel	Farbe Finish / Couleur	Länge (mm) Length / Longueur	Art.-Nr./No./ N° d'art.
<b>Laufschiene</b> Running track / Rail de roulement		<b>Aluminium eloxiert</b> Anodized aluminium Aluminium anodisé	<b>Silber eloxiert</b> Anodized silver Argent anodisé	1000	01-975-001-100
				3000	01-975-001-300
<b>Führungsschiene</b> Guiding track / Rail de guidage		<b>Aluminium eloxiert</b> Anodized aluminium Aluminium anodisé	<b>Silber eloxiert</b> Anodized silver Argent anodisé	1000	01-975-002-100
				3000	01-975-002-300
<b>Vertikales Profil</b> Vertical profile / Profil vertical		<b>Aluminium eloxiert</b> Anodized aluminium Aluminium anodisé	<b>Metalllicgrau lackiert</b> Painted metallic grey Peint en gris métallique	2500	01-975-003-250
<b>Vertikales Profil mit Griffleiste</b> Vertical profile with handle bar / Profil vertical avec poignée barre		<b>Aluminium eloxiert</b> Anodized aluminium Aluminium anodisé	<b>Metalllicgrau lackiert</b> Painted metallic grey Peint en gris métallique	2500	01-975-004-250
<b>Eckverbinder</b> Corner connector / Connecteur d'angle		<b>Aluminium eloxiert</b> Anodized aluminium Aluminium anodisé	<b>Originalfarbe 304</b> Original color Couleur d'origine	1 Stk./ pcs./piè	1-975-900-001